

## PRE-CONSTRUCTION CONFERENCE MINUTES

Date: October 24, 2023  
 Project No.: PE23190

1) **PROJECT:** City of Brooklet  
2023 Brooklet Street Improvements Project

2) **OWNER:** City of Brooklet  
104 Church Street  
Brooklet, GA 30415

Phone: (912) 842-2136  
 Fax: -

	Contact	Description
Owner's Rep:	<u>Lori Phillips, City Clerk</u> (912) 842-2136 <u>lori.phillips@brookletga.us</u>	<u>Office</u> <u>Email</u>
Owner's Rep:	<u>Nicky Gwinnett</u> (912) 682-4084 <u>nicky.gwinnett@brookletga.us</u>	<u>Cell</u> <u>Email</u>
Owner's Rep:	<u>Derrell Smith (Public Works)</u> (912) 531-4726 <u>publicworks@brookletga.us</u>	<u>Cell</u> <u>Email</u>
Owner's Rep:	<u>Gary Roberts, Chief of Police</u> 912-844-6967 =	<u>Cell</u> <u>Email</u>

3) **CONTRACTOR:** McLendon Enterprises, Inc.  
2365 Aimwell Road  
Vidalia, GA 30474

Phone: (912) 537-7887

Project Manager:	<u>Sean Scott</u> (912) 682-1535 <u>sean@mclendonenterprises.com</u>	<u>Cell</u> <u>Email</u>
Project Manager:	<u>Keith Clemments</u> (912) 326-1462 <u>keith@mclendonenterprises.com</u>	<u>Cell</u> <u>Email</u>
Project Manager:	<u>Shane Holland</u> (912) 537-7887 (912) 293-6026 <u>shane@mclendonenterprises.com</u>	<u>Office</u> <u>Cell</u> <u>Email</u>
Project Manager:	<u>Kenny Allen</u> (478) 299-0596 <u>kenny@mclendonenterprises.com</u>	<u>Cell</u> <u>Email</u>
Project Manager:	<u>Miles Cason</u> (912) 245-1661 <u>miles@mclendonenterprises.com</u>	<u>Cell</u> <u>Email</u>

4) **ENGINEER:** Parker Engineering, LLC  
36 Courtland St., Suite B  
Statesboro, Georgia 30458

Phone: (912) 764-7722  
 Fax: (912) 764-6960

Principal in Charge:	<u>Wesley Parker, P.E.</u> (912) 687-1203 <u>wesley@parker-engineering.com</u>	<u>Cell</u> <u>Email</u>
POC:	<u>Lindsey Bashlor</u> (912) 481-3181 <u>lindsey@parker-engineering.com</u>	<u>Cell</u> <u>Email</u>

5) **Responsibilities of ENGINEER:**

- a) Represents Owner and issues all instructions of Owner.
- b) Reviews and approves construction schedule and shop drawings; however, Engineer is not construction scheduler or expeditor.
- c) Supervises Resident Project Representative. Limits of Representative's duties are listed in General Conditions and Supplemental Conditions.
- d) Observes work for compliance with drawings and specifications only.
- e) Determines amount earned for payment, and reviews and approves pay estimates and change orders.
- f) Initial judge of all claims and disputes.
- g) Certifies project completion.

6) **Responsibilities of OWNER:**

- a) Ultimate decision maker on disputes of Contract Sum and Contract time.
- b) Does not instruct Contractor in day-to-day work, except in emergencies.
- c) Approves pay estimates and change orders and pays contractor on schedule.
- d) Maintain accurate cost records.

7) **Responsibilities of CONTRACTOR:** (The Contractor's responsibilities are fully spelled out by the Contract Documents and are not modified by this pre-construction conference.)

- a) Does the Contractor accept job site and conditions? \_\_\_\_\_ yes
- b) Contractor insurance in order prior to starting work? \_\_\_\_\_ yes
- c) Complete construction within time limit.
- d) The Contractor is fully responsible for construction means and methods.
- e) Maintain continuous clean-up.
- f) The Contractor is fully responsible for SAFETY of workers, the job site, subs and the public.
- g) Obtain written prior approval from Engineer before making changes. All change orders will be written.
- h) Must supervise subcontractors and coordinate all Work with any utility companies.
- i) Must call for utility location at least 72 hours prior to beginning any excavation and grading.
- j) Superintendent with authority to make decisions must be on job site at all times.

8) **Application for Payment procedures:** (Copy back to Contractor w/payment)

- a) Number of copies of Application for Payment?   1
- b) Quantities must be measured with Field Representative present.
- c) Contractor may submit payment once per 30 days.
- d) Copies of partial Payment Estimate should be signed by the Contractor and forwarded to Engineer. Engineer will review Estimate, sign and forward to the Owner. Engineer will copy Contractor and Administrator with approved Estimate and transmittal letter.
- e) Contractor should submit the following information on Stored Materials:  
One (1) copy of Summary for each Estimate submitted for a total of   1   copies.  
One (1) copy of invoices to be retained by Engineer.

9) **Comments/Questions**

1. Lindsey Bashlor - Make sure and coordinate with Whitaker Labs for testing on Parker Street and Railroad Street only.
2. Trash pick up for the south side of Hwy 80 is on Monday, and trash pick up on the north side of Hwy 80 is on Tuesday.
3. Checks are cut every 1st and 3rd week of the month.
4. Upon visiting E. Lane Street, we would like to propose an addition of paving E. Lane Street from N. Cromley Road to Waters Street. There will also be an addition of widening on N. Cromley Street (at the northeast intersection of W. Lane Street) and paving Cromley Street from Hwy 80 to Brooklet Leefield Road which will include overlay and the removal and replacement of speed bumps. McLendon is going to get us an official change order for these additions by November 8th.

5. Thanksgiving break for Brooklet Elementary School is November 20-24, so E. Lane Street paving can either be done during this time, or we can have the chief of police redirect school traffic if need be. McLendon will confirm their schedule and let us know.

6. While at Parker Avenue, we noted that we are going to get Whitaker Labs to take cores to know how much can mill to make sure that we pave on a solid base even with the existing gutter. After the meeting, I spoke with Whitaker Labs, and they will be coming Friday, 10/27/23 to take cores so that they can provide us with testing results by Wednesday, November 1st. We will work with Peek Pavement Marking's schedule to see how quick they can come to town to stripe after asphalt is put down.

7. McLendon Enterprises will be delivering all millings from the project to West Lane Street, Brooklet, GA 30415. This is the northern dirt portion of the road. Nicky informed the contractor that he could dump the millings, and the City would spread them.

10) **Notice to Proceed**

Notice to Proceed date for start of work	<u>November 21, 2023</u>	
Substantial Completion Contract Time:	<u>75</u>	days
Substantial Completion Date:	<u>February 4, 2024</u>	
Final Completion Contract Time:	<u>90</u>	days
Final Completion Date:	<u>February 19, 2024</u>	
EPD Approval of plans and specs:	<u>N/A</u>	

11) **Procedure for extension of Contract Time spelled out in General Conditions.**

12) **Liquidated Damages amount:** \$300 per calendar day.

13) **Any foreseeable problems with schedule?** No.

14) **Shop Drawings**

- a) Number of Copies 1
- b) Contractor to submit to Engineer for Review
- c) Distribution to be made by engineer as follows:
  - Owner - One (1) copy
  - Engineer - One (1) copy
  - Contractor - Two (2) copies

15) **Are there any other questions about:**

- a) General or Supplementary Conditions? No
- b) Summary of Work? No
- c) Basic requirements? No
- d) Special project procedures? No
- e) Work hours? Daylight Hours.
- f) Notice must be given for overtime and holiday/weekend work. Ok
- g) Engineer's role? No.
- h) Retainage. (10% retainage for up to 50% of work completed.) No.

16) **Questions about Drawings and Specifications?** No

17) **What is starting point? What is sequence of Work?**

18) **Other issues or questions:**

A. Stockpile / Storage Areas:

B. Spoil Areas:

C. Parking:



<b>CONTRACT FOR: 2023 Brooklet Striping Project</b>	<b>PROJECT NO.:</b>	<b>PE23193</b>
<b>OWNER: City of Brooklet</b>	<b>ORDER NO.:</b>	<b>1</b>
<b>TO: Peek Pavement Marking, LLC</b>	<b>DATE:</b>	<b>October 30, 2023</b>
<b>4600 Peek Industrial Drive</b>	<b>STATE:</b>	<b>Georgia</b>
<b>Columbus, GA 31909</b>	<b>COUNTY:</b>	<b>Bulloch</b>

You are hereby requested to comply with the following changes from the contract plans and specifications:

ITEM NO.	DESCRIPTION	QTY	UNIT	PRICE	DECREASE in Contract Price	INCREASE in Contract Price
1c.	Delete 24" Stop Bar, Paint	53	EA	\$ 25.00	\$ 1,325.00	
1d.	Add Thermoplastic Solid Traffic Stripe, 24" White	53	EA	\$ 100.00		\$ 5,300.00
NET CHANGE IN CONTRACT PRICE =					\$1,325.00	\$5,300.00
TOTAL INCREASE IN CONTRACT PRICE =						\$3,975.00

**Justification:** Replacing 24" stop bar paint with 24" thermoplastic solid stop bars.

The amount of the contract prior to this change order:

Forty thousand seventy five dollars and zero cents.

( \$40,075.00 )

The amount of the contract will increase by the sum of:

Three thousand nine hundred seventy five dollars and zero cents.

( \$3,975.00 )

The contract total including this and previous change orders will be:

Forty four thousand fifty dollars and zero cents.

( \$44,050.00 )

This document will become a supplement to the contract and all provisions will apply hereto.

\_\_\_\_\_  
City of Brooklet

\_\_\_\_\_  
(Date)

*Lindsey Bashlor*  
\_\_\_\_\_  
Parker Engineering, LLC

10/30/2023  
\_\_\_\_\_  
(Date)

\_\_\_\_\_  
Peek Pavement Marking, LLC

\_\_\_\_\_  
(Date)





# Landscape Project Estimate

Estimate # : 4670  
 Date: 10/27/2023  
 Valid Until: 11/10/2023  
 Code: 8E898794

## Billing Information

City of Brooklet  
 PO Box 67  
 Brooklet, GA 30415

## Service Property Information

City of Brooklet  
 104 Church St  
 Brooklet, GA 30415

Estimate Description	Quantity	Rate	Amount
Pickup/Delivery (per Trip)	1	100.00	100.00
Ground Prep for Plant Install ( <i>Hrly / \$80 Minimum</i> )	1.5	80.00	120.00
Plant Installation ( <i>Hrly</i> )	2.5	80.00	200.00
Annuals (4")	60	6.25	375.00
Juniper - 'Blue Point' - 3gal	1	31.50	31.50
Mulch: Bagged 'Brown' Hardwood Mulch (2 CuFt)	4	6.65	26.60
Bio-Tone Starter Plus (per 3gal plant)	1	1.35	1.35

Project estimate is \$854.45 (*plus Sales Tax \$0.00*) ... or **\$854.45** total.

*Due to volatile price conditions, we may require 65% deposit IN HAND to schedule most projects that exceed \$1000*

Any deposit or pre-payment submitted for this project will be applied to the final invoice, which will represent the actual charges.

**NOTE:** Even though we attempt to measure & estimate as close as possible, estimated amounts will often vary slightly from actual amounts and this should be expected. If the actual install will vary from an estimate, and it is practical to do so (*in our judgement*), we will confirm with you before proceeding. An example would be if we estimated 50 pallets of sod, and your project will take 51 pallets to cover the desired space. An example of where it is not practical would be if we estimate 50 bales of straw, and your project requires 51 bales to cover the desired space. The major difference is the cost of the variation vs. the job disruption to confirm minor variations. On multi-estimate projects, labor hours are considered "shared" across all phases of the larger project and we will not exceed that estimated total without express confirmation.

### SPECIAL NOTE:

Due to current supply chain issues, which are having an effect on almost all items, we now have a shortened time period for estimate validity AND we reserve the option to adjust prices during your project work, since some prices are changing too fast to lock-in costs until products are actually purchased and/or picked up for your job. This does not affect the labor charges, only materials.

*\*\* If your "line" for requiring change confirmation differs, simply let us know and we will consider restricting such "judgement calls".*

**Thank you for allowing Ninja Lawns to serve you!**

Below we have listed the next steps that you'll follow as you review your estimate...

### STEP 1

Please review the services we have quoted above. If you are unclear on some matter or we missed something, please let us know. Note that many services may be "grouped" and not itemized.

### STEP 2

[Click here to view your proposal](#)  
 Review the estimate. If multiple line items are contained in one estimate, be sure that all desired items are checked (*left-hand column*) prior to online approval. Let us know of any questions.

### STEP 3

(Chose to **Accept Proposal** - Bottom of page)  
 OR contact our staff who will add your new service into our schedule ONCE DEPOSIT IS RECEIVED.  
 We may contact you to share the expected schedule and answer any questions that you may have.

### A Brief Overview of Our Billing Process:

**One-Time Services** (*like property clean-up services, installation of plants, straw, mulch, etc.*) are routinely invoiced in advance if charges are easily known. Larger or complex projects are invoiced once completed, but may require full or partial pre-payment of estimated charges prior to being scheduled for a crew. Put simply, this serves as a way to confirm we are all *on the same page* on a project. If you're ready to move forward, payment shouldn't be an issue... or we need to schedule for later.

We look forward to serving you to "Master the Art of Lawn Care" on your property. As always, if you have any questions or concerns (with our work, policies, attitudes, or this estimate), please call us at 912-226-7646 or shoot us an [email](#).

NinjaLawns.com | Customers@NinjaLawns.com  
 912-226-7646 | 855-55-NINJA  
 Ninja Lawns, Inc. - PO Box 350 - Sylvan, GA 30467



Lori Phillips <lori.phillips@brookletga.us>

---

**Fwd: Quote for cemetery**

---

**Consider it Done Lawn Maint** <consideritdonelawn@gmail.com>  
To: Lori Phillips <lori.phillips@brookletga.us>

Fri, Oct 27, 2023 at 4:00 PM

I didn't realize the other side. It would 400.00 a cut.  
[Quoted text hidden]





## Review your proposal

Review each line item. Then just click the accept button to confirm and set up service.

Review the proposal below. Check any services that you want.



Turf Pros, Inc.  
P.O. Box 779  
Brooklet, Ga. 30415

City of Brooklet  
202 East Lee St.  
Brooklet, GA 30415

Dear City of Brooklet:

**Winter Preemergence**

This application will be performed between now and the end of November of 2023. This application is designed to prevent weeds from surfacing during the winter months. This application will also include insecticide for insects such as ants, mole crickets and grubs.

Amount: 725.00

**Spring preemergence**

This application will be performed one time during the months of January to March of 2024. This application is designed to help prevent weeds from surfacing during the spring and summer months. This application will also include insecticide for insects such as ants and mole crickets.

Amount: 725.00

**Winter Preemergence**

This application will be performed one time during the months of September to November of 2024. This application is designed to prevent weeds from surfacing during the winter months. This application will also include insecticide for insects such as ants, mole crickets and grubs.

Amount: 725.00

Thank you for the opportunity to prepare this proposal. We hope to hear from you soon.

Sincerely,

Jim Branch  
Turf Pros, Inc.  
P.O. Box 779  
Brooklet, GA. 30415  
912-871-8873  
912-536-3816  
jim@turfprosga.com



# Bid Proposal for MXUs

CUSTOMER

**TOWN OF BROOKLET**

202 EAST LEE STREET  
BROOKLET, GA 30415

**Job**

MXUs  
Bulloch, GA  
Bid Date: 10/17/2023  
Bid #: 3178406

CONTACT

**Sales Representative**

Laura Rogers  
(M) 912-944-7361  
(T) 912-748-3484  
(F) 912-748-9406  
Laura.Rogers@coreandmain.com

**Core & Main**

550 Jimmy Deloach Parkway  
Suite 120  
Savannah, GA 31407  
(T) 912-748-3484

NOTES



Bid Proposal for MXUs

TOWN OF BROOKLET  
Job Location: Bulloch, GA  
Bid Date: 10/17/2023  
Core & Main 3178406

Core & Main  
550 Jimmy Deloach Parkway  
Suite 120  
Savannah, GA 31407  
Phone: 912-748-3484  
Fax: 912-748-7686

Seq#	Qty	Description	Units	Price	Ext Price
10	27	520M S/POINT M2 TC SP HR & LD 5396353752201MI	EA	150.00	4,050.00
				<b>Sub Total</b>	<b>4,050.00</b>
				Tax	0.00
				<b>Total</b>	<b>4,050.00</b>

UNLESS OTHERWISE SPECIFIED HEREIN, PRICES QUOTED ARE VALID IF ACCEPTED BY CUSTOMER AND PRODUCTS ARE RELEASED BY CUSTOMER FOR MANUFACTURE WITHIN THIRTY (30) CALENDAR DAYS FROM THE DATE OF THIS QUOTATION. CORE & MAIN LP RESERVES THE RIGHT TO INCREASE PRICES TO ADDRESS FACTORS, INCLUDING BUT NOT LIMITED TO, GOVERNMENT REGULATIONS, TARIFFS, TRANSPORTATION, FUEL AND RAW MATERIAL COSTS. DELIVERY WILL COMMENCE BASED UPON MANUFACTURER LEAD TIMES. ANY MATERIAL DELIVERIES DELAYED BEYOND MANUFACTURER LEAD TIMES MAY BE SUBJECT TO PRICE INCREASES AND/OR APPLICABLE STORAGE FEES. THIS BID PROPOSAL IS CONTINGENT UPON BUYER'S ACCEPTANCE OF SELLER'S TERMS AND CONDITIONS OF SALE, AS MODIFIED FROM TIME TO TIME, WHICH CAN BE FOUND AT: <https://coreandmain.com/TandC/>

Sometimes the pump  
won't lift the tube boom.

After talking to the  
ODB Rep.

The list of parts  
on page 1 could be the  
problem.

It would be better  
price wise, to replace  
entire pump

876.<sup>00</sup>

# 10.3 M259 Hydraulic Boom Pump

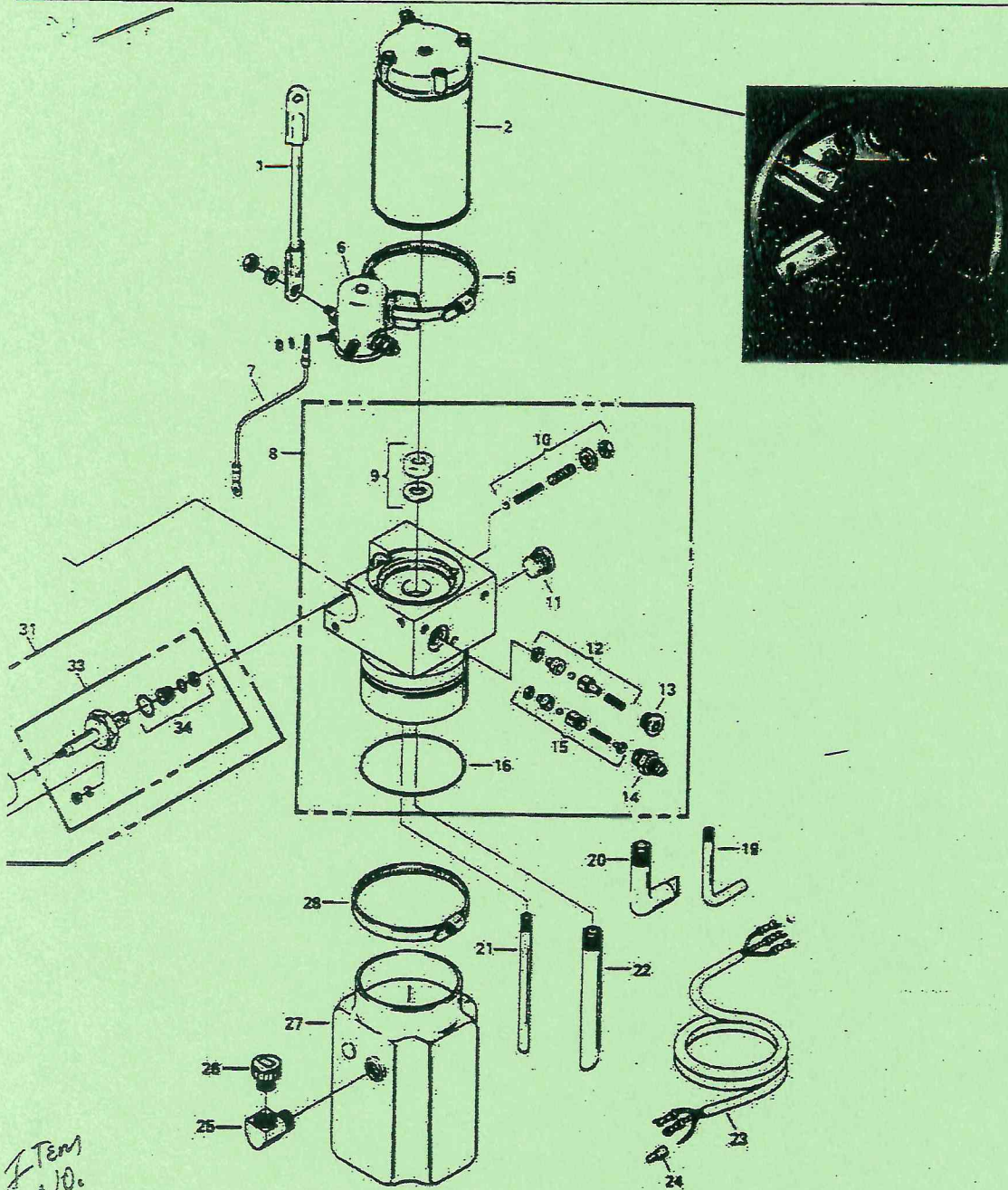

Item No.

PART NUMBER	DESCRIPTION
2 MP-08053 435 <sup>00</sup>	Electric Motor, 12V
3A MP-08684	Brush Set, 3 brushes & end cap 2001 and before
24 MP-08711 118 <sup>00</sup>	Brush Set, 3 brushes & end cap 2002 and after
6 MP-03335	Solenoid Switch, 4 post, curved (controls up movement)
6 MP-17744 95 <sup>00</sup>	Solenoid Switch, heavy duty
23 MP-03773	Cord, Harness, 144" Long
27 MP-06231	Plastic Reservoir
256 <sup>00</sup> 31 <del>MP-00488</del> MP192830	Electric Valve, (controls down movement)
32 MP-00496	Coil, 2 way- 2 position

\*Call ODB for any part not listed.

will need old # off of it - There are 2 of these

# 10.3 M3219 Hydraulic Boom Pump

08/12 and after

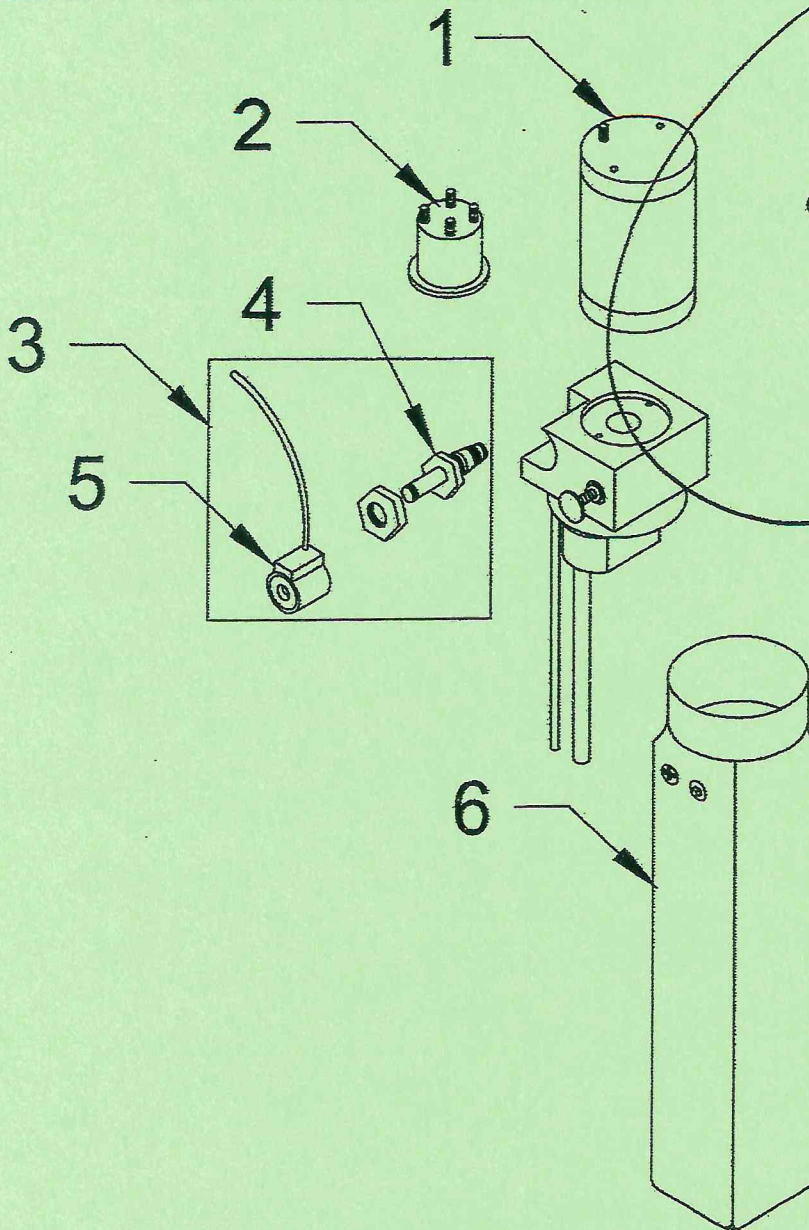

Cost is  
\$ 876.00

~~FA Price~~

ITEM NO.	PART NUMBER	DESCRIPTION
	MP-M3219.S	Complete Pump Assembly (all above)
1.	MP-08004	Electric Motor, 12V
2.	MP-17744	Solenoid Switch, heavy duty
3.	MP-19283.D	Coil, Cartridge Assembly
4.	MP-07193D	Cartridge
5.	MP-1 0861.D	Coil, 2 way- 2 position
6.	MP-06232	Plastic Reservoir, 3.5" x 15.7"

\*Call ODB for any part not listed.



Gary M. Roberts &lt;gary.roberts@brookletga.us&gt;

---

**Flock - Brooklet PD Follow Up**

1 message

---

**Alysha Stanton** <alysha.stanton@flocksafety.com>  
To: Gary Roberts <gary.roberts@brookletga.us>

Wed, Nov 1, 2023 at 11:37 AM

Chief Roberts,

It was a pleasure speaking with you today. Per our conversation, I wanted to share some pricing information with you as well as some resources you can share with your city council.

Standard pricing is \$3,000/camera per year plus the one-time installation fee of \$650/camera. For access to the ALPR network (FlockOS Essentials), it's \$15,000 annually OR if you purchase 5 Falcon LPRs or more, it's free. See quote below for reference.

Here is the promo we're offering:

*Any new or existing customers are eligible to purchase three (3) Flock Safety Falcons for only \$9,999.00, including twelve (12) months of FlockOS Essentials package.\* After initial twelve (12) months, standard pricing applies.*

*\* Offer subject to applicable taxes. Offer limited to Existing Infrastructure and Standard Implementation only. Advanced Implementation not included and subject to additional costs.*

*Minimum purchase required. Offer ends 12/31/2023. Cannot be combined with any other offer. Offer details subject to change at Flock Safety's sole discretion without notice. Terms and conditions apply.*

Your install would be a standard install so you could get the 3 cameras for \$9999 plus the FlockOS Essentials package. (Let me know if you'd like a quote for the promo offer).

Lastly, you can turn on GA DOR hits on your cameras and use them for expired tags and citations.

Let me know if you have any questions.

Alysha

---

**Alysha Stanton**

Revenue Enablement Manager, Law Enforcement Lead



---

(678) 294-9804 [flocksafety.com](https://flocksafety.com)

---

**flock safety**

---

**3 attachments** **Brooklet PD.pdf**  
3536K **Falcon LPR Overview (1).pdf**  
5119K **Flock Safety Quote\_Standard Pricing Brooklet PD.pdf**  
114K

flock safety

# Flock Safety Falcon<sup>®</sup> LPR



Eliminate crime on every roadway with  
hassle-free LPR.

## PROBLEM

Without key evidence, like a license plate or vehicle description,  
many cases go unsolved.

## SOLUTION

Flock Safety Falcon<sup>®</sup> LPR cameras provide vehicle data, real-time alerts,  
searchable evidence, and analytics to improve police response and  
investigations 24/7.

**Solve more cases faster with Flock's effective and trusted LPR technology.**

1

### IMPROVE EFFICIENCY AND MAXIMIZE INVESTMENT WITH A ONE-STOP-SHOP

With one annual subscription fee, Flock Safety covers hardware procurement, permitting, deployment planning, policy creation, installation, maintenance, user training, customer support, and software upgrades.

2

### CUT COSTS WITH PUBLIC-PRIVATE PARTNERSHIPS

Flock Safety brings LPR to neighborhoods and businesses, providing law enforcement privately-funded access to actionable evidence.

3

### GAIN TRUST WITH BUILT-IN DATA GUARDRAILS

Our LPR is designed for secure, responsible use with customized user permissions, usage audits, and limited data retention. Devices only capture vehicle data, not people, to mitigate bias and accelerate case clearance. Your agency owns 100% of the data, and we never sell it to third parties.



# flock safety

Trusted by thousands of law enforcement agencies.

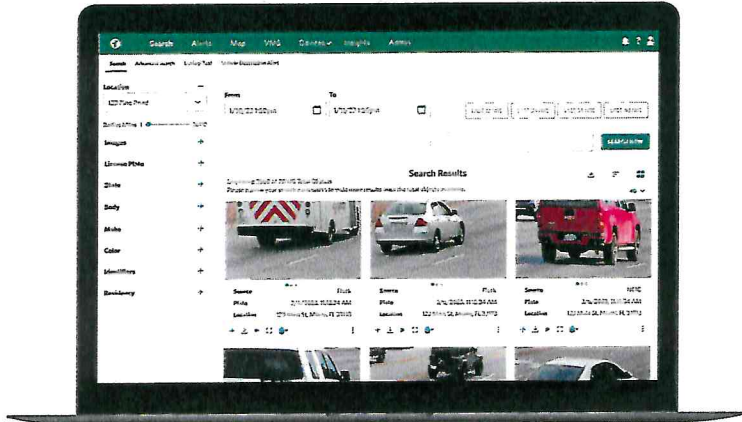

Cobb County, GA  
Police Dept

Fort Worth, TX  
Police Dept

Wichita, KS  
Police Dept

Riverside County, CA  
Sheriff's Dept

## Key Features & Functionality

### SEARCH

Search full, partial, and temporary plates by time and location.

### VEHICLE FINGERPRINT®

Filter by Flock's patented Vehicle Fingerprint® attributes:  
Vehicle make | Body type | Color | State Registration  
Decals | Bumper stickers | Back racks | Top racks

### LOCATION-BASED SEARCH

Perform single and multi-location-based searches to link a suspect vehicle to one, or multiple crime scenes.

### CONVOY ANALYSIS

Identify associate suspect vehicles with convoy analysis.

### REAL-TIME ROUTING

Determine possible vehicle path of travel with Real-Time Routing Analysis.

### CUSTOM ALERTS

Automate email, text, and in-app alerts from custom and shared Hot Lists (i.e. NCIC).

### HOT LIST SHARING

Create and share hot lists.

### ACCESS EXTERNAL ALPR DATA

Access external ALPR databases:  
FBI NCIC | NCMEC Amber Alert | REJIS | CCIC & more

### CJIS COMPLIANT

Meet CJIS security policy compliance.

### AUDIT TRAIL

- Capture required reason for search field capture.
- Report on user behavior for audits and positive outcomes for proof of ROI.

### MOBILE APP

Access the FlockOS mobile companion app.

flock safety

flocksafety.com  
(866) 901-1781 | support@flocksafety.com

flock safety

# Eliminate crime and shape a safer future, together

MM.DD.YYYY | Rep Name, Title



# Customers in the Area:

Statesboro PD  
Georgia Southern PD  
Effingham CSO  
Pooler PD  
Port Wentworth  
Savannah PD  
Garden City PD  
Tybee Island PD  
Claxton PD  
Bloomingdale PD  
Bryan CSO  
Richmond Hill PD

# Falcon

LPR

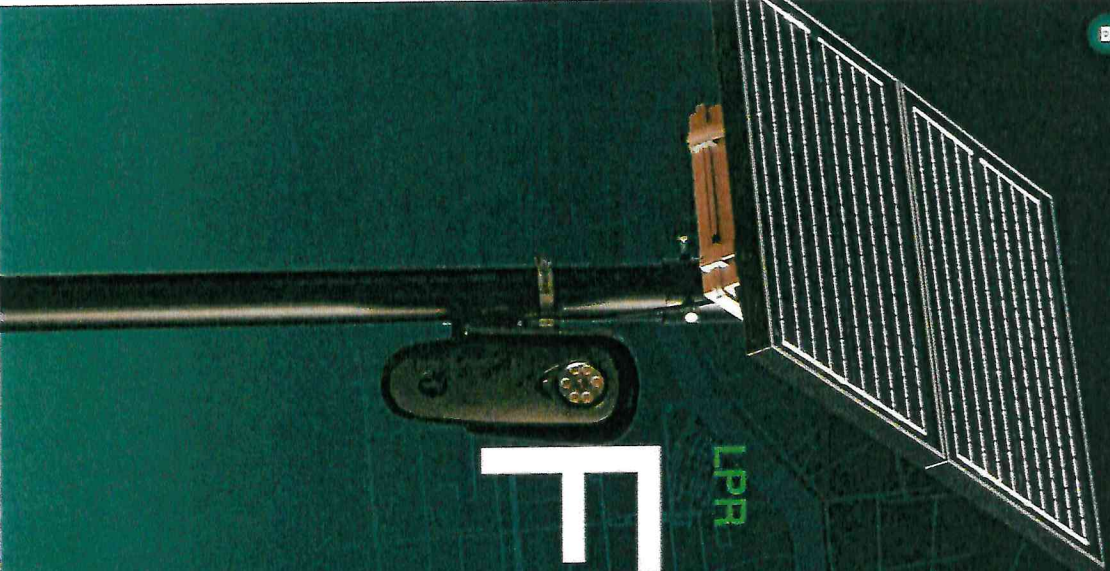
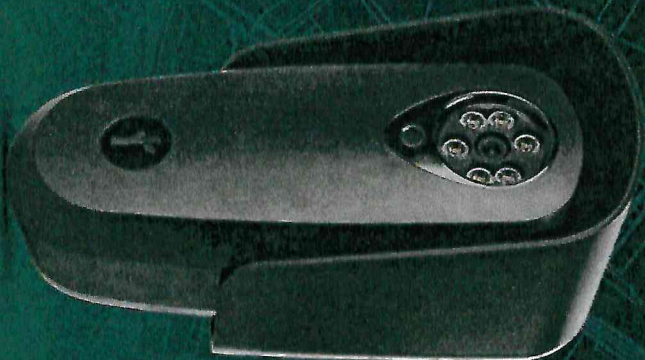

Block safety

# Eliminate crime on every roadway

Never miss a lead with Falcon® License Plate Recognition for all roads, including high-speed and multi-lane freeways, parking lots, tactical applications, and more.

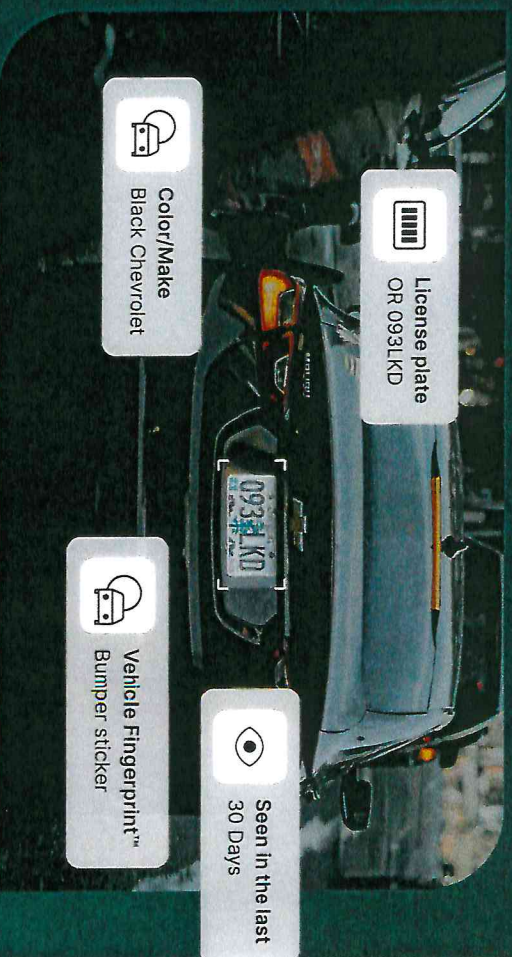

## INFRASTRUCTURE-FREE

Reduce time to value and utility costs with full-service deployment.



## 24/7 COVERAGE

Capture objective vehicle data around the clock to multiply your force.



## REAL-TIME ALERTS

- NCIC
- NCMEC (Amber Alert)
- Custom Hot Lists
- Hot List sharing



## END-TO-END SERVICE

- Hardware
- Permitting
- Installation & Maintenance
- Training

**Crime doesn't respect jurisdictions**

**10B+**

plate reads  
every month

**Expand your network to clear more cases**

**flock safety**

# Solve crime, we'll handle the rest

Our customers experience fast time to value because our dedicated team provides rapid, full-service deployment.

Ditch the headaches and upfront investments associated that come with multiple vendors.

## Get it all with your Flock Safety annual subscription:

- Solar power (no utility costs)\*
- Installation + Ongoing Maintenance
- Hardware Procurement + Permitting
- User Training
- Data storage
- Software Updates

*\*Falcon LR is AC-powered, Falcon Flex is battery-powered*



**flock safety**

# App-based intelligence on the go

When every moment counts, clarity matters. The Flock Safety app delivers fast, accurate intel at your fingertips for confident decision-making on patrol.

Available for iOS and Android

## FEATURES

- Hot List Alerts
- Audio Detection Alerts
- License Plate Lookup
- Hot List Verification via Image Upload
- Shift Mode
- Notifications by Radius
- Smartwatch Notifications
- Single Sign-On (SSO)



flock safety



# Standard Pricing

<b>Falcon</b>
<b>Annual Cost</b> \$3,000
<b>Installation</b> Existing Infrastructure: \$150 <b>Standard Flock Pole: \$650</b> Advanced: \$1900

<b>Software/Network Pricing</b>
<b>Annual Cost</b> \$15,000
<b>Includes Access to 10B+ Plate reads per month across the country</b>